



2.5Gbps Laser Driver with Automatic Modulation Control

MAX3865†

General Description

The MAX3865 is designed for direct modulation of laser diodes at data rates up to 2.5Gbps. It incorporates two feedback loops, the automatic power-control (APC) loop and the automatic modulation-control (AMC) loop, to maintain constant average optical output and extinction ratio over temperature and laser lifetime. External resistors or current output DACs may set the laser output levels. The driver can deliver up to 100mA of laser bias current and up to 60mA laser modulation current with a typical (20% to 80%) edge speed of 84ps.

The MAX3865 accepts differential clock and data input signals with on-chip 50Ω termination resistors. The inputs can be configured for CML or other high-speed logic. An input data-retiming latch can be enabled to reject input pattern-dependent jitter when a clock signal is available. The MAX3865 provides laser bias current and modulation current monitors, as well as a failure detector, to indicate the laser operating status. These features are all implemented on an 80mil x 120mil die; the MAX3865 is also available as a 32-pin QFN package.

Applications

- SONET/SDH Transmission Systems
- Add/Drop Multiplexers
- Digital Cross-Connects
- Section Regenerators
- 2.5Gbps Optical Transmitters

Features

- ◆ Single +3.3V or +5V Power Supply
- ◆ 68mA Supply Current
- ◆ Up to 2.5Gbps (NRZ) Operation
- ◆ Feedback Control for Constant Average Power
- ◆ Feedback Control for Constant Extinction Ratio
- ◆ Programmable Bias Current Up to 100mA
- ◆ Programmable Modulation Current Up to 60mA
- ◆ 84ps Rise/Fall Time
- ◆ Selectable Data Retiming Latch
- ◆ Bias and Modulation Current Monitors
- ◆ Failure Detector
- ◆ ESD Protection

Ordering Information

PART	TEMP. RANGE	PIN-PACKAGE
MAX3865EGJ	-40°C to +85°C	32 QFN-EP*
MAX3865E/D	-40°C to +85°C	Dice**

*EP = exposed paddle.

**Dice are designed to operate from -40°C to +85°C, but are tested and guaranteed at $T_A = +25°C$ only. Contact factory for availability.

Pin Configuration appears at end of data sheet.

Typical Applications Circuit

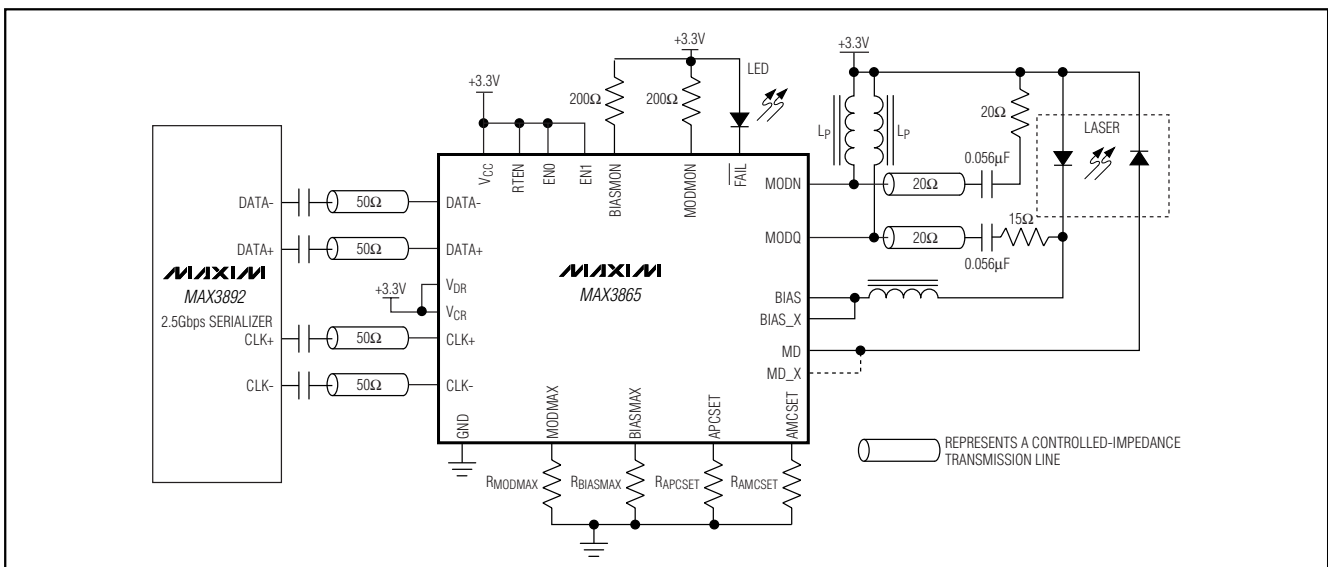

† Covered by U.S. Patent numbers 5,883,910, 5,850,409, and other patent pending.



For pricing, delivery, and ordering information, please contact Maxim/Dallas Direct! at 1-888-629-4642, or visit Maxim's website at www.maxim-ic.com.

2.5Gbps Laser Driver with Automatic Modulation Control

ABSOLUTE MAXIMUM RATINGS

Voltage at Any Pin+7.0V
 Supply Voltage (V_{CC})-0.5V to +7.0V
 Voltage at V_{CR} , V_{DR} , DATA+, DATA-,
 CLOCK+, and CLOCK- Pins-0.5V to ($V_{CC} + 0.5V$)
 Voltage at DATA+ and
 DATA- Pins($V_{DR} - 1.2V$) to ($V_{DR} + 1.2V$)
 Voltage at CLK+ and CLK- Pins($V_{CR} - 1.2V$) to ($V_{CR} + 1.2V$)
 Voltage at MODQ and MODN Pins0V to ($V_{CC} + 1.5V$)
 Voltage at Any Other Pins (RTEN, EN0, EN1, \overline{FAIL} ,
 MODMAX, BIASMAX, AMCSET, APCSET, MD_X, BIAS,
 BIAS_X, BIASMON, MODMON)-0.5V to ($V_{CC} + 0.5V$)

Current into BIAS Pin-20mA to +150mA
 Current into MODQ and MODN Pins-20mA to +100mA
 Current into MD Pin-10mA to +10mA
 Operating Junction Temperature-55°C to +150°C
 Storage Temperature Range-55°C to +150°C
 Continuous Power Dissipation ($T_A = +85^\circ\text{C}$)
 32-Pin QFN (derate 21.2mW/°C above +85°C)1.3W
 Lead Temperature (soldering, 10s)+300°C
 Processing Temperature (die)+400°C

Stresses beyond those listed under "Absolute Maximum Ratings" may cause permanent damage to the device. These are stress ratings only, and functional operation of the device at these or any other conditions beyond those indicated in the operational sections of the specifications is not implied. Exposure to absolute maximum rating conditions for extended periods may affect device reliability.

ELECTRICAL CHARACTERISTICS

($V_{CC} = +3.14V$ to +3.6V or +4.5V to +5.5V, $T_A = -40^\circ\text{C}$ to +85°C. Typical values are at $V_{CC} = +3.3V$, $I_{BIAS} = 50\text{mA}$, $I_{MOD} = 30\text{mA}$, $T_A = +25^\circ\text{C}$, unless otherwise noted.) (Notes 1, 2, 3)

PARAMETER	SYMBOL	CONDITIONS	MIN	TYP	MAX	UNITS	
Power-Supply Current	I_{CC}	$V_{CC} = +3.14V$ to +3.6V (Note 4)		68	85	mA	
		$V_{CC} = +4.5V$ to +5.5V, typical current at $V_{CC} = +5.0V$ (Note 4)		69	90		
Differential Input Voltage	V_{ID}	Data and clock inputs (Figure 2)	0.2		1.6	Vp-p	
Instantaneous Input Voltage		Data and clock inputs (Figure 2) (Note 5)	+1.3		$V_{CC} + 0.4V$	V	
Single-Ended Input Resistance		Input to V_{DR} , V_{CR}	40	50	60	Ω	
Input Return Loss, for Data+, Data-, Clock+, and Clock-	RL_{IN}	$f \leq 2.7\text{GHz}$		20		dB	
		$2.7\text{GHz} < f < 4\text{GHz}$		17			
Bias-Current Setting Range			1		100	mA	
Bias Off Current		EN0, EN1 = low			0.1	mA	
Bias-Current Setting Accuracy		APC off		$I_{BIAS} = 100\text{mA}$	± 15	%	
				$I_{BIAS} = 1\text{mA}$	± 0.1	mA	
Compliance Voltage for BIAS and BIAS_X		(Note 5)	+1		$V_{CC} + 0.4$	V	
BIAS to BIASMON Ratio				48		mA/mA	
Modulation-Current Setting Range	I_{MOD}		5		60	mA	
Modulation Off Current		EN0, EN1 = low			0.1	mA	
Modulation-Current Setting Accuracy		AMC off		$I_{MOD} = 60\text{mA}$	± 15	%	
				$I_{MOD} = 5\text{mA}$	± 0.25	mA	
Compliance Voltage for MODQ and MODN		(Note 5)		$+3.14V \leq V_{CC} \leq +3.6V$	+1.8	$V_{CC} + 1.5$	V
				$+4.5V \leq V_{CC} \leq +5.5V$		+5.5	
I_{MOD} to I_{MODMON} Ratio				32		mA/mA	
Compliance Voltage for BIASMON and MODMON		(Note 5)	+1.8		$V_{CC} + 0.4$	V	
Voltage at MD Pin	V_{MD}			1.0		V	

2.5Gbps Laser Driver with Automatic Modulation Control

MAX3865

ELECTRICAL CHARACTERISTICS (continued)

(V_{CC} = +3.14V to +3.6V or +4.5V to +5.5V, T_A = -40°C to +85°C. Typical values are at V_{CC} = +3.3V, I_{BIAS} = 50mA, I_{MOD} = 30mA, T_A = +25°C, unless otherwise noted.) (Notes 1, 2, 3)

PARAMETER	SYMBOL	CONDITIONS	MIN	TYP	MAX	UNITS
Bias-Setting Accuracy at MD Pin		$I_{MD} = 1\text{mA}$		±15		%
		$I_{MD} = 36\mu\text{A}$		±10		μA
Modulation-Setting Accuracy at MD Pin		(Note 6)	$I_{MD} = 1\text{mA}$	±15		%
			$I_{MD} = 36\mu\text{A}$	±10		μA
EN0, EN1, and RTEN Input High			2.0			V
EN0, EN1, and RTEN Input Low					0.8	V
$\overline{\text{FAIL}}$ Output High		Source 50μA	2.4			V
$\overline{\text{FAIL}}$ Output Low		Sink 100μA			0.4	V
$\overline{\text{FAIL}}$ Current		Low state, V_{OL} forced to V_{CC}			5.0	mA
Setup/Hold Time	t_{SU}, t_{HD}	(Figure 2) (Note 5)	100			ps
Output Edge Speed	t_R, t_F	Load = 20Ω, 20% to 80% (Notes 5, 7)		84	130	ps
Output Overshoot		(Notes 5, 7)		9		%
Enable/Startup		APC and AMC off		150		ns
Maximum CID		(Notes 2, 5)	80			bit
Deterministic Jitter		(Notes 2, 5)		22	50	psp-p
Random Jitter		(Notes 5, 7)		1.6		psRMS
AMC Pilot Tone Frequency	f_{AMC}			1		MHz

Note 1: AC characterization performed using the circuit in Figure 1.

Note 2: Measured using a 2.5Gbps 2¹³ - 1 PRBS with 80 0's and 80 1's input data pattern.

Note 3: Specifications at -40°C are guaranteed by design and characterization.

Note 4: V_{CC} current excludes the current into MODQ, MODN, BIAS, BIAS_X, MODMON, and BIASMON pins.

Note 5: Guaranteed by design and characterization.

Note 6: Measured with low-frequency data. Instantaneous current into MD pin range is 36μA to 1000μA.

Note 7: Measured using a 2.5Gbps repeating 0000 0000 1111 1111 pattern.

2.5Gbps Laser Driver with Automatic Modulation Control

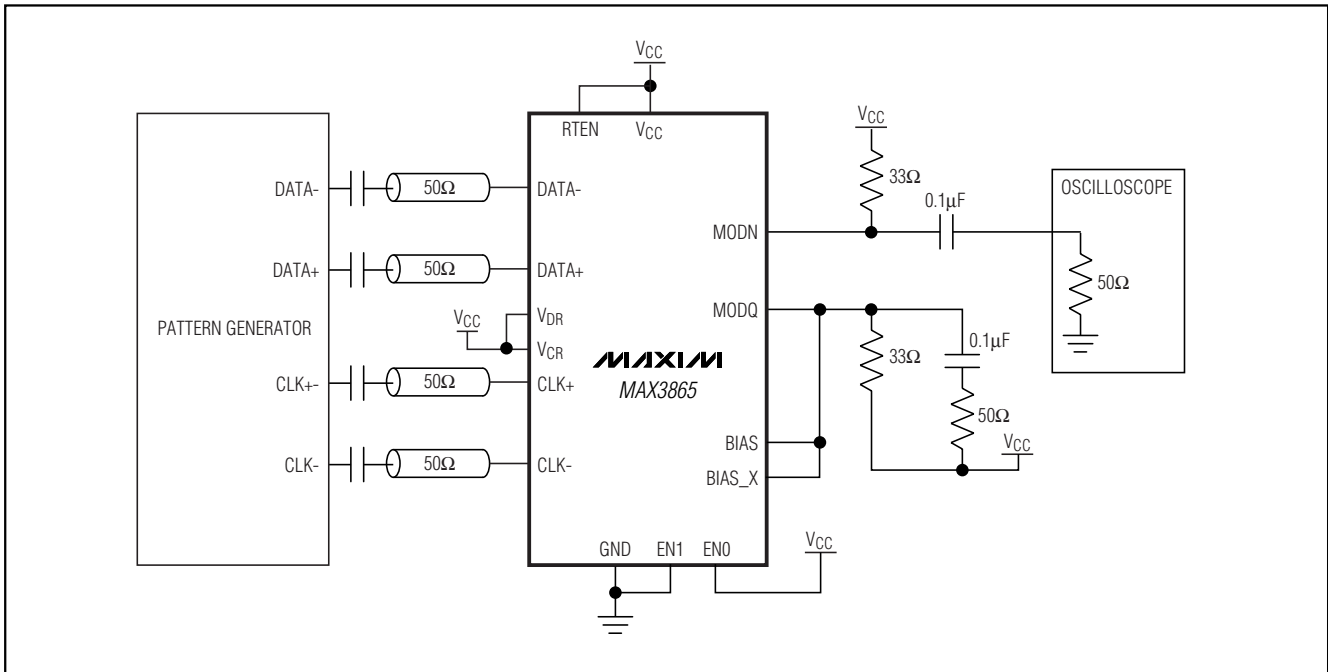

Figure 1. Test Circuit

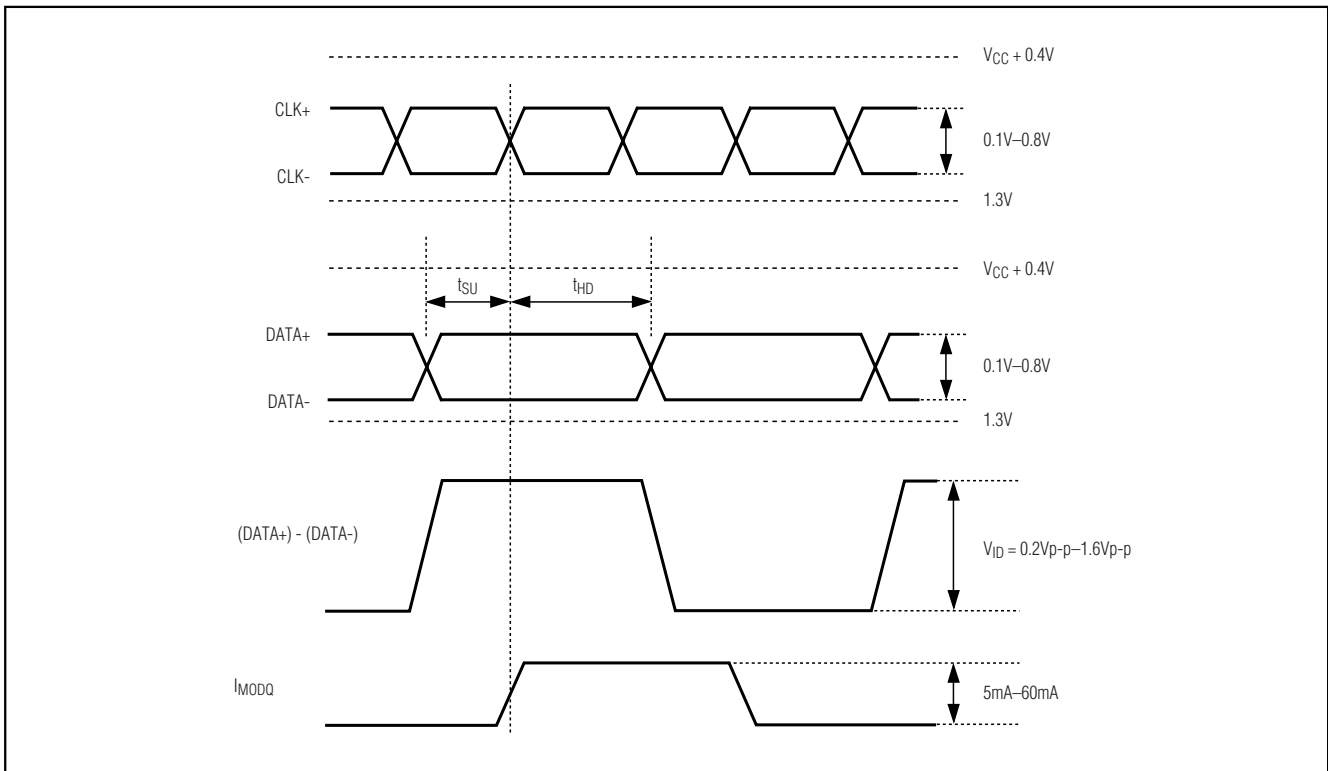

Figure 2. Required Input Signal, Setup/Hold-Time Definition, and Output Polarity

2.5Gbps Laser Driver with Automatic Modulation Control

Typical Operating Characteristics

($T_A = +25^\circ\text{C}$, unless otherwise noted.)

MAX3865

OPTICAL EYE DIAGRAM
(EXTINCTION RATIO = 8.25dB,
2¹³-1 PRBS AT 2.5Gbps, 1.87GHz FILTER)

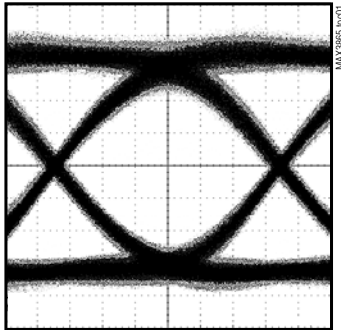

58ps/div

ELECTRICAL EYE DIAGRAM
($I_{MODQ} = 60\text{mA}$)

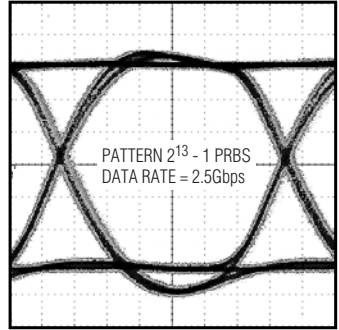

58ps/div

ELECTRICAL EYE DIAGRAM
($I_{MODQ} = 30\text{mA}$)

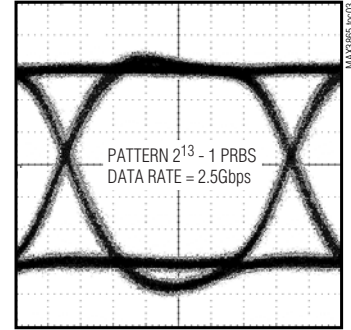

58ps/div

SUPPLY CURRENT (I_{CC}) vs. TEMPERATURE
(EXCLUDES BIAS AND MODULATION CURRENTS)

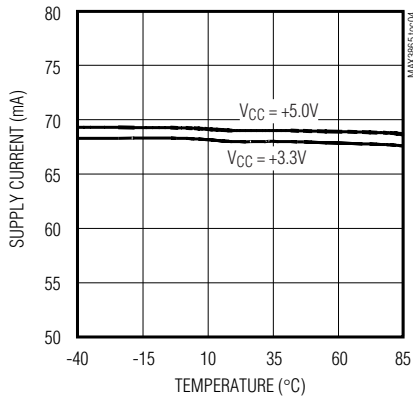

DETERMINISTIC JITTER
vs. TEMPERATURE ($I_{MODQ} = 60\text{mA}$)

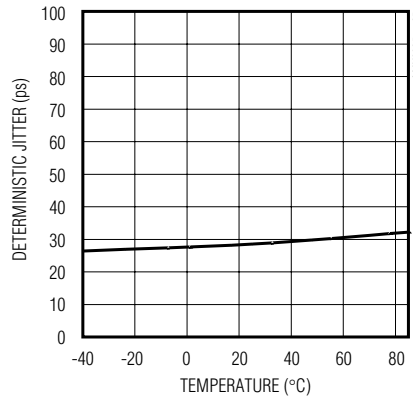

TYPICAL DISTRIBUTION OF RISE TIME
(WORST-CASE CONDITIONS)

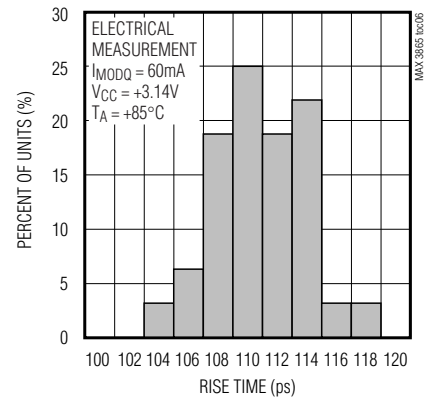

TYPICAL DISTRIBUTION OF FALL TIME
(WORST-CASE CONDITIONS)

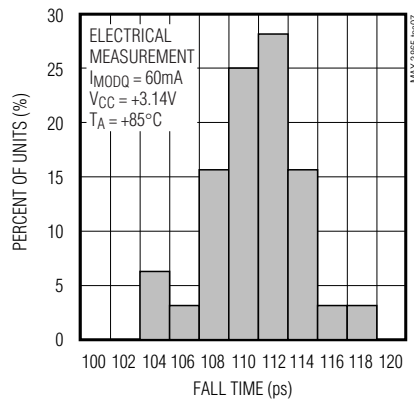

DIFFERENTIAL IS111 vs. FREQUENCY

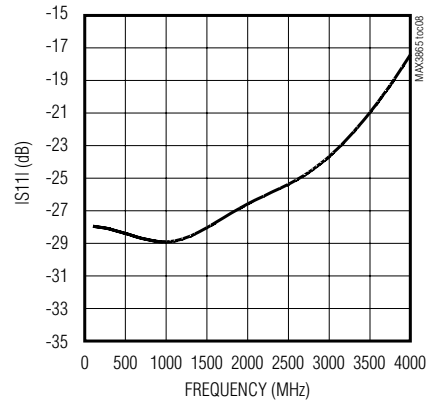

2.5Gbps Laser Driver with Automatic Modulation Control

Pin Description

PIN	NAME	FUNCTION
1, 8, 19, 22, 28	VCC	Positive Supply Voltage
2	DATA-	Complementary Data Input, with On-Chip Termination
3	DATA+	Data Input, with On-Chip Termination
4	VDR	Termination Reference Voltage for Data Inputs
5	VCR	Termination Reference Voltage for Clock Inputs
6	CLK+	Clock Input for Data Retiming, with On-Chip Termination
7	CLK-	Complementary Clock Input for Data Retiming, with On-Chip Termination
9, 16, 23, 24, 25	GND	No Internal Connection. Tie to ground.
10	RTEN	Data Retiming Enable Input, TTL Compatible, Active-High
11	EN0	Operating Mode Input, TTL Compatible
12	EN1	Operating Mode Input, TTL Compatible
13	FAIL	Fault Warning, TTL Compatible. Low for fault condition.
14	BIASMON	Bias-Current Monitor. Open-collector type, tie to VCC if not used.
15	MODMON	Modulation-Current Monitor. Open-collector type, tie to VCC if not used.
17	BIAS_X	Bias Shunt. Always tie to the BIAS pin.
18	BIAS	Laser Bias-Current Output. Connect to the laser via an inductor.
20	MODN	Modulation-Current Output to Dummy Load
21	MODQ	Modulation-Current Output to Laser
26	MD	Feedback Input from Monitor Diode
27	MD_X	Monitor Diode Shunt. Connect to GND when laser diode to monitor current gain ≤ 0.005 . Connect to the MD pin for gain ≥ 0.02 . For $0.005 < \text{gain} < 0.02$ connect to either GND or the MD pin.
29	AMCSET	Monitor Diode Modulation-Current (Peak-to-Peak) Set Point
30	APCSET	Monitor Diode Bias-Current (Average) Set Point
31	MODMAX	Connect an external resistor to ground to program I_{MOD} in the MANUAL and APC modes. The resistor sets the maximum I_{MOD} in AMC mode. The AMC loop may reduce I_{MOD} from its maximum but cannot add to it.
32	BIASMAX	Connect an external resistor to ground to program I_{BIAS} in the MANUAL mode. The resistor sets the maximum I_{BIAS} in the APC and AMC modes. The APC loop may reduce I_{BIAS} from its maximum but cannot add to it.
EP	Exposed Paddle	The exposed paddle and corner pins must be soldered to ground.

2.5Gbps Laser Driver with Automatic Modulation Control

Table 1. Mode Selection

EN0	EN1	OPERATING MODE	DESCRIPTION
0	0	Shutdown	Bias and modulation currents off
1	0	APC	APCSET programs laser bias, MODMAX programs modulation
1	0	APC	APCSET programs laser bias, MODMAX programs modulation
1	1	AMC	AMCSET programs modulation current and APCSET programs bias

Detailed Description

The MAX3865 laser driver consists of two main parts: a high-speed modulation driver and biasing block as shown in Figure 4. Outputs to the laser diode are a switched modulation current and a steady bias current. Two servo loops may be enabled to control bias and modulation currents for constant optical power and extinction ratio.

The MAX3865 requires a laser with a built-in monitor diode to provide feedback about the optical output. The average laser power, as sensed by the monitor diode, is controlled by the APC servo loop. Peak-to-peak modulation current is controlled by the AMC servo loop. The modulation output stage uses a programmable current source with a maximum current of 60mA. A high-speed differential pair switches this source to the laser diode. The clock and data inputs to the modulation driver may use CML, PECL, and other logic levels. The optional clock signal can be used to synchronize data transitions for minimum pattern-dependent jitter.

Clock/Data Input Logic Levels

The MAX3865 is directly compatible with V_{CC} -referenced CML. Other logic interfaces are possible. For V_{CC} -referenced CML or AC-coupled logic, tie V_{DR} and V_{CR} to V_{CC} . For other DC-coupled differential signals, float V_{DR} and V_{CR} (Figure 5). To prevent excess power dissipation in the input matching resistors, keep the instantaneous input voltage within 1.2V of V_{DR} or V_{CR} as specified in the electrical characteristics.

Optional Input Data Retiming

To eliminate pattern-dependent jitter in the input data, a synchronous differential clock signal should be connected to the CLK+ and CLK- inputs, and the RTEN control input should be tied high. Input data retiming occurs on the rising edge of CLK+. If RTEN is tied low, the retiming function is disabled and the input data is directly connected to the output stage. When no clock is available, tie CLK+ to V_{CC} , ground CLK- through a 1.5k Ω resistor, and leave V_{CR} open.

Operating Mode

The MAX3865 can be set in four operating modes, depending on applications requirements. Mode selection is by two TTL-compatible inputs (see Table 1).

APC Loop

In APC mode, a servo loop maintains the average current from the monitor diode at a level set by the APCSET input. Laser bias current is varied in this mode to maintain the monitor diode current. The BIASMAX input must be set to a value larger than the maximum expected bias current. In this mode, BIASMAX limits the maximum bias current to the laser if the control loop fails. The $\overline{\text{FAIL}}$ pin will go low if average $I_{MD} \neq I_{APCSET}$.

Mark-Density Compensation

Average power control assumes 50% mark density for times greater than about 100ns. For long patterns or situations where 50% mark density does not apply, the MAX3865 provides mark-density compensation. The APCSET reference is increased by an amount proportional to the mark density multiplied by the modulation amplitude. The AMCSET input is used as an estimate of the peak-to-peak modulation current when the mark density is not 50%. Mark-density compensation is active in both APC and AMC control modes.

AMC Loop

In AMC mode, a servo loop maintains the peak-to-peak current from the monitor diode at a level set by the AMCSET input. Laser modulation current is varied in this mode to maintain the monitor diode current. The MODMAX input must be set to a value larger than the maximum expected modulation current. In this mode, MODMAX limits the maximum modulation current to the laser if the control loop fails. The $\overline{\text{FAIL}}$ pin will go low if peak-to-peak $I_{MD} \neq I_{AMCSET}$. The APC loop is active when in the AMC mode. In AMC mode, mark-density compensation is automatic.

2.5Gbps Laser Driver with Automatic Modulation Control

Warning Outputs

A TTL-compatible, active-low warning flag, FAIL, is set when:

- One or more of the programmable currents is set at greater than 150% of the rated maximum for the chip. A shorted programming resistor would cause this warning. In this case, the bias and modulation outputs are shut down to protect the laser.
- Average $I_{MD} \neq I_{APCSET}$ in the APC or AMC mode. This could be caused by too low a setting for maximum I_{BIAS} or by a laser that has exceeded its useful life.
- Peak-to-peak $I_{MD} \neq I_{AMCSET}$ in the AMC mode. This could be caused by too low a setting for I_{MODMAX} or by a laser which has exceeded its useful life.

The FAIL flag also is set for a few microseconds following power-up, until the servo loops settle. The BIASMON and MODMON pins can be used to monitor the laser current and predict the end of the useful laser life before a failure occurs.

Design Procedure

When designing a laser transmitter, the optical output is usually expressed in terms of average power and extinction ratio. Table 2 gives relationships that are helpful in converting between the optical power and the

Table 2. Optical Power Relations

PARAMETER	SYMBOL	RELATION
Average Power	P_{AVG}	$P_{AVG} = (P_0 + P_1)/2$
Extinction Ratio	r_e	$r_e = P_1/P_0$
Optical Power of a "1"	P_1	$P_1 = 2P_{AVG} \times r_e / (r_e + 1)$
Optical Power of a "0"	P_0	$P_0 = 2P_{AVG} / (r_e + 1)$
Optical Amplitude	P_{p-p}	$P_{p-p} = P_1 - P_0$
Laser Slope Efficiency	η	$\eta = P_{p-p}/I_{MOD}$
Laser to Monitor Diode Transfer	ρ_{MON}	$\rho_{MON} = I_{MD} / P_{AVG}$

Note: Assuming a 50% average input duty cycle and mark density.

modulation current. These relationships are valid if the mark density and duty cycle of the optical waveform are 50%.

For a desired laser average optical power, P_{AVG} , and optical extinction ratio, r_e , the required modulation current can be calculated based on the laser slope efficiency, η , using the equations in Table 2.

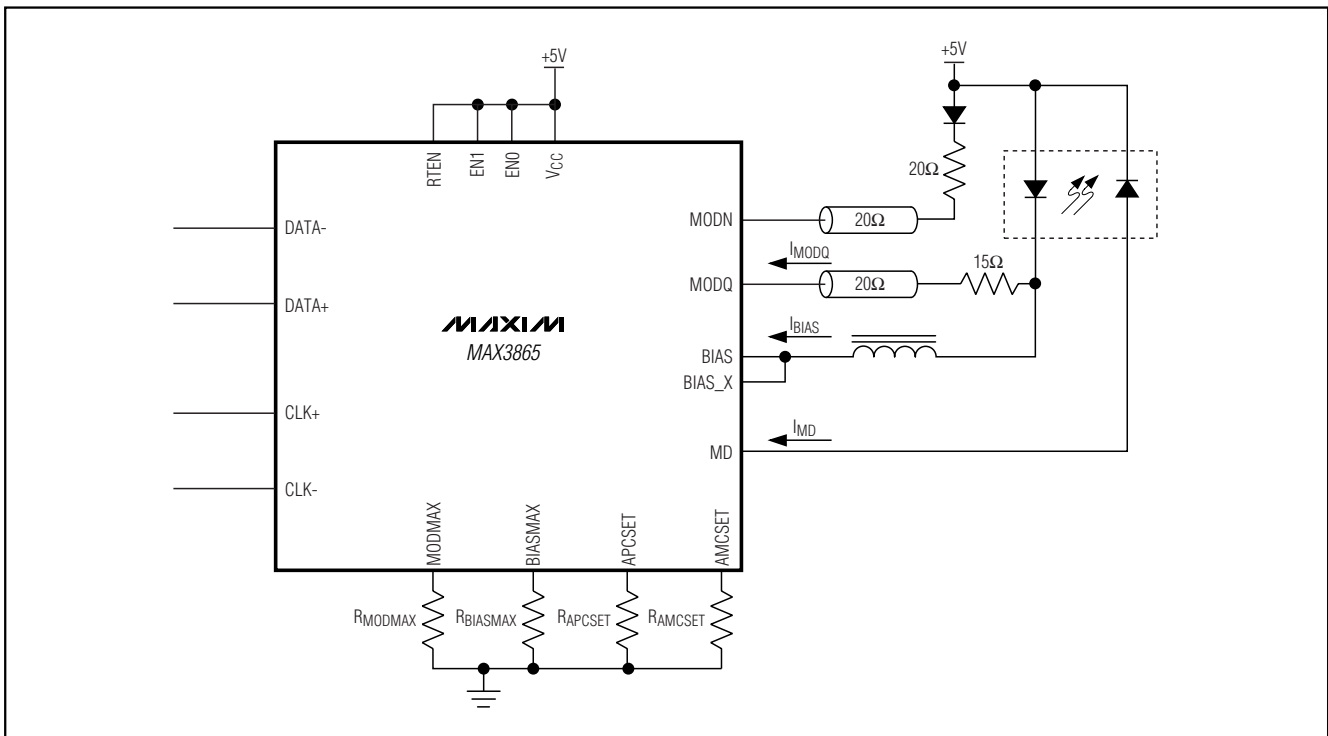

Figure 3. DC-Coupled Laser Circuit

2.5Gbps Laser Driver with Automatic Modulation Control

Laser Current Requirements

Bias and modulation current requirements can be determined from the laser threshold current and slope efficiency. The modulation and bias currents under a single operating condition are:

$$I_{MOD} = 2 \times \frac{P_{AVG}}{\eta} \times \frac{r_e - 1}{r_e + 1}$$

- For DC-coupled laser diodes:

$$I_{BIAS} > I_{TH}$$

where I_{TH} is the laser threshold current.

- For AC-coupled laser diodes:

$$I_{BIAS} > I_{TH} + \frac{I_{MOD}}{2}$$

Given the desired parameters for operation of the laser diode, the programming of the MAX3865 is explained in the following text.

Current Limits

To keep the modulation current in compliance with the programmed value, the following constraint on the total modulation current must be made:

DC-Coupled Laser Diodes:

$$V_{CC} - V_{DIODE} - I_{MOD} \times (R_D + R_L) - I_{BIAS} \times R_L \geq 1.8V$$

- For V_{DIODE} —Laser diode bias point voltage (1.2V typ)
- R_L —Laser diode bias-point resistance (5Ω typ)
- R_D —Series matching resistor (15Ω typ)

AC-Coupled Laser Diodes:

To allow larger modulation current, the laser can be AC-coupled to the MAX3865 as shown in the *Typical Application Circuit*. In this configuration, a constant current is supplied from the inductor L_P . The requirement for compliance in the AC-coupled circuit is as follows:

$$V_{CC} - \frac{I_{MOD}}{2} \times (R_D + R_L) \geq 1.8V$$

The AC-coupling capacitor and bias inductor form a second-order high-pass circuit. Pattern-dependent jitter results from the low-frequency cutoff of this high-pass circuit. To prevent ringing:

$$(R_D + R_L) \geq 2 \times \sqrt{\frac{L_P}{C}}$$

For deviation from 50% duty cycle or for runs of consecutive identical digits (CID), the low-frequency corner

formed by the LC circuit must be low enough to limit the droop.

$$\text{Droop} = \frac{\text{Number_CID}}{\text{Data_Rate} \times \sqrt{L_P} \times C}$$

If droop = 6.7%, number_CID = 100 and data_rate = 2.5Gbps, then possible values for L_P and C may be $L_P = 6\mu H$ and $C = 0.056\mu F$. Both L and C must be increased in value to reduce droop without ringing.

Programming the Maximum Bias Current

In AMC (or APC) mode, the bias current needs a limit if the loop becomes open. $R_{BIASMAX}$ sets the maximum allowed bias current. The bias current is proportional to the current through $R_{BIASMAX}$. An internal current regulator maintains the band-gap voltage of 1.2V across the programming resistors. Select the maximum I_{BIAS} programming resistor as follows:

$$I_{BIASMAX} = 480 \times \frac{1.2V}{R_{BIASMAX} + 2k\Omega}$$

Alternatively, a current DAC forcing I_{DAC} from the $BIASMAX$ pin may set the current maximum:

$$I_{BIASMAX} = 480 \times I_{DAC}$$

When the AMC or APC loop is enabled, the actual bias current is reduced below the maximum value to maintain a constant average current from the monitor diode. With closed-loop control, the bias current will be determined by the transfer function of the monitor diode to laser-diode current. For example, if the transfer function to the monitor diode is 10.0μA/mA, then setting I_{MD} for 500μA will result in I_{BIAS} equal to 50mA.

In manual mode, the bias current I_{BIAS} is $I_{BIASMAX}$ as set by $R_{BIASMAX}$.

Programming the Average Monitor Diode-Current Set Point

The $APCSET$ pin controls the set point for the average monitor diode current when in AMC or APC mode. The $APCSET$ current is externally established in the same manner as the $BIASMAX$ pin. The average monitor diode current I_{MD} can be programmed with a resistor as follows:

$$\text{average_}I_{MD} = 5 \times \frac{1.2V}{R_{APCSET} + 2k\Omega}$$

Alternatively, a current DAC at the $APCSET$ pin can set the monitor diode current by:

$$\text{average } I_{MD} = 5 \times I_{DAC}$$

2.5Gbps Laser Driver with Automatic Modulation Control

Mark-Density Compensation in APC Mode

When mark density is expected to deviate from 50% for periods exceeding 5% of the APC time constant, the AMCSET pin should be programmed to compensate the APC set point. The time constant is determined by the laser to monitor diode gain.

$$\tau_{APC} = \frac{1.5\text{ns}}{G_{MD}}$$

$$G_{MD} = \frac{\Delta I_{MONITOR}}{\Delta I_{LASER}}$$

(For example, $\tau_{APC} = 150\text{ns}$ for $G_{MD} = 0.01\text{mA/mA}$.)

Set the estimated peak-to-peak monitor diode current by the following equation:

$$\text{estimated } I_{MD(p-p)} = 5 \times \frac{1.2\text{V}}{R_{AMCSET} + 2\text{k}\Omega}$$

Alternatively, a current DAC at the AMCSET pin can set the monitor diode current by:

$$\text{Extended } I_{MD(p-p)} = 5 \times I_{DAC}$$

Programming the Maximum Modulation Current

In AMC mode, the modulation current needs a limit if the loop becomes open. R_{MODMAX} sets the maximum allowed modulation current. The modulation current is proportional to the current through R_{MODMAX} . Select the maximum I_{MOD} programming resistor as follows:

$$I_{MODMAX} = 320 \times \frac{1.2\text{V}}{R_{MODMAX} + 2\text{k}\Omega}$$

Alternatively, a current DAC forcing I_{DAC} from the $MODMAX$ pin may set the current maximum

$$I_{MODMAX} = 320 \times I_{DAC}$$

When the AMC loop is enabled, the actual modulation current is reduced from the maximum value to maintain constant peak-to-peak current from the monitor diode. With closed-loop control, the modulation current will be determined by the transfer function of the monitor diode to laser diode current. For example, if the transfer function to the monitor diode is $10.0\mu\text{A/mA}$, then setting I_{MD} for $500\mu\text{A}$ will result in I_{MOD} equal to 50mA .

In manual mode, the modulation current I_{MOD} is set by R_{MODMAX} .

Table 3. Connection of the MD_X Pin

LASER-TO-MONITOR DIODE-CURRENT GAIN	MD_X SHUNT CONNECTION
<0.005	GND
0.005 to 0.02	GND or MD
>0.02	MD

Programming the Peak-to-Peak Monitor Diode-Current Set Point

The AMCSET pin controls the set point for the peak-to-peak monitor diode current in AMC mode. The peak-to-peak value of the monitor diode current can be programmed with a resistor as follows:

$$I_{MD(p-p)} = 5 \times \frac{1.2\text{V}}{R_{AMCSET} + 2\text{k}\Omega}$$

Alternatively a current DAC at the AMCSET pin can set the monitor diode current by:

$$I_{MD(p-p)} = 5 \times I_{DAC}$$

Laser Gain Compensation

The MAX3865 may be used in closed-loop operation with a wide variety of laser-to-monitor diode gains. Table 3 shows the connection of the MD_X pin for different current-gain ranges.

Current Monitor Outputs

The MAX3865 provides bias and modulation current monitors. The BIASMON output sinks a current proportional to the bias current:

$$I_{BIASMON} = \frac{I_{BIAS}}{48}$$

The MODMON pin sinks a current proportional to the laser modulation current:

$$I_{MODMON} = \frac{I_{MOD}}{32}$$

The BIASMON and MODMON pins should not be allowed to drop below 1.8V. They should be tied to V_{CC} when not in use.

2.5Gbps Laser Driver with Automatic Modulation Control

MAX3865

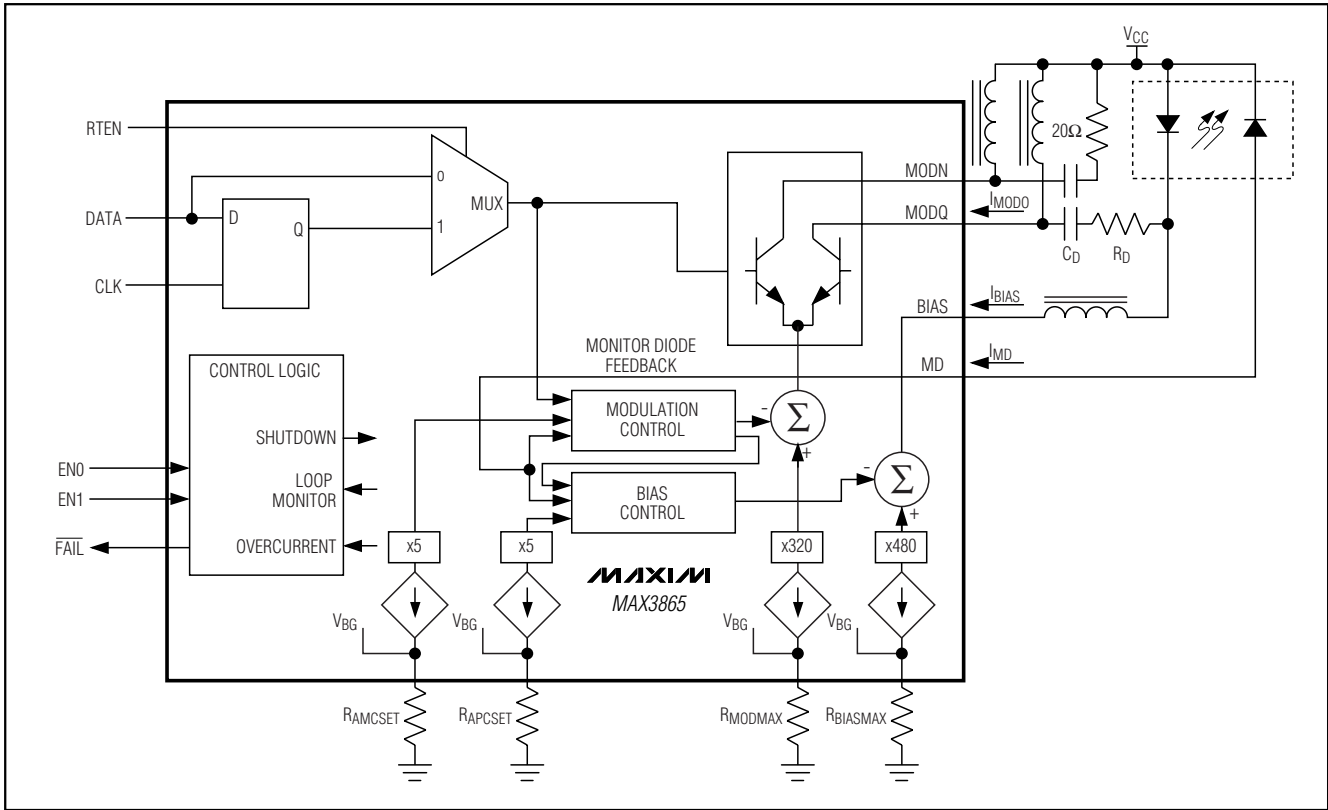

Figure 4. Functional Diagram

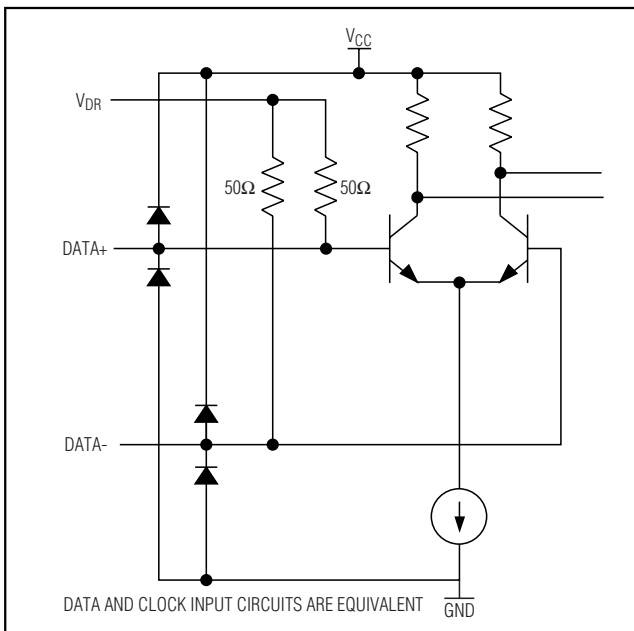

Figure 5. Equivalent Input Circuit

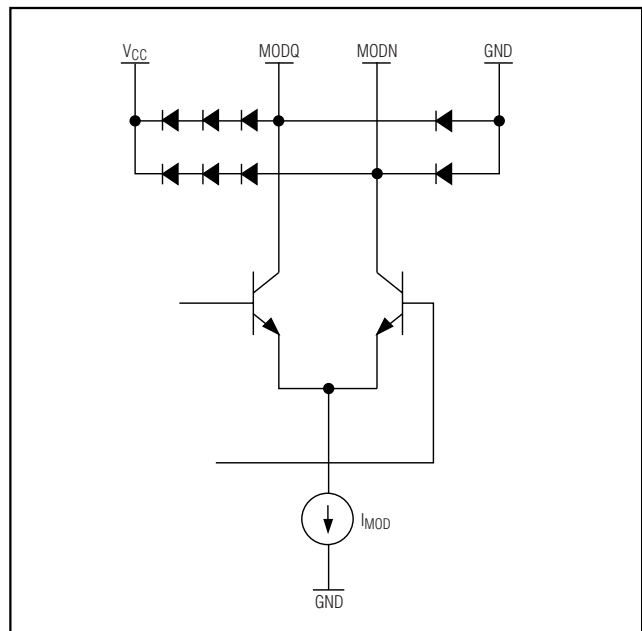

Figure 6. Equivalent Modulation Output Circuit

2.5Gbps Laser Driver with Automatic Modulation Control

Applications Information

Layout Considerations

To minimize loss and crosstalk, keep the connections between the MAX3865 output and the laser diode as short as possible. Use good high-frequency layout techniques and multilayer boards with uninterrupted ground plane to minimize EMI and crosstalk. Circuit boards should be made using low-loss dielectrics. Use controlled-impedance lines for the clock and data inputs as well as the modulation output.

References

For further information, refer to the application notes for fiber optic circuits, HFAN-02, on the Maxim web page.

Laser Safety and IEC 825

Using the MAX3865 laser driver alone does not ensure that a transmitter design is compliant with IEC 825. The entire transmitter circuit and component selections must be considered. Each customer must determine the level of fault tolerance required by their application,

recognizing that Maxim products are not designed or authorized for use as components in systems intended for surgical implant into the body, for applications intended to support or sustain life, or for any other application where the failure of a Maxim product could create a situation where personal injury or death may occur.

Chip Information

TRANSISTOR COUNT: 1690

Substrate Connected To GND

PROCESS: Bipolar

DIE SIZE: 81mil × 103mil

Pin Configuration

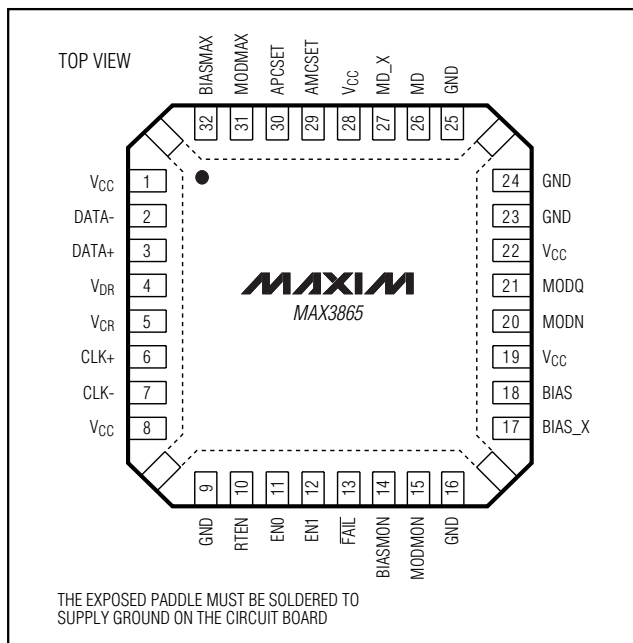

2.5Gbps Laser Driver with Automatic Modulation Control

Chip Topography

MAX3865

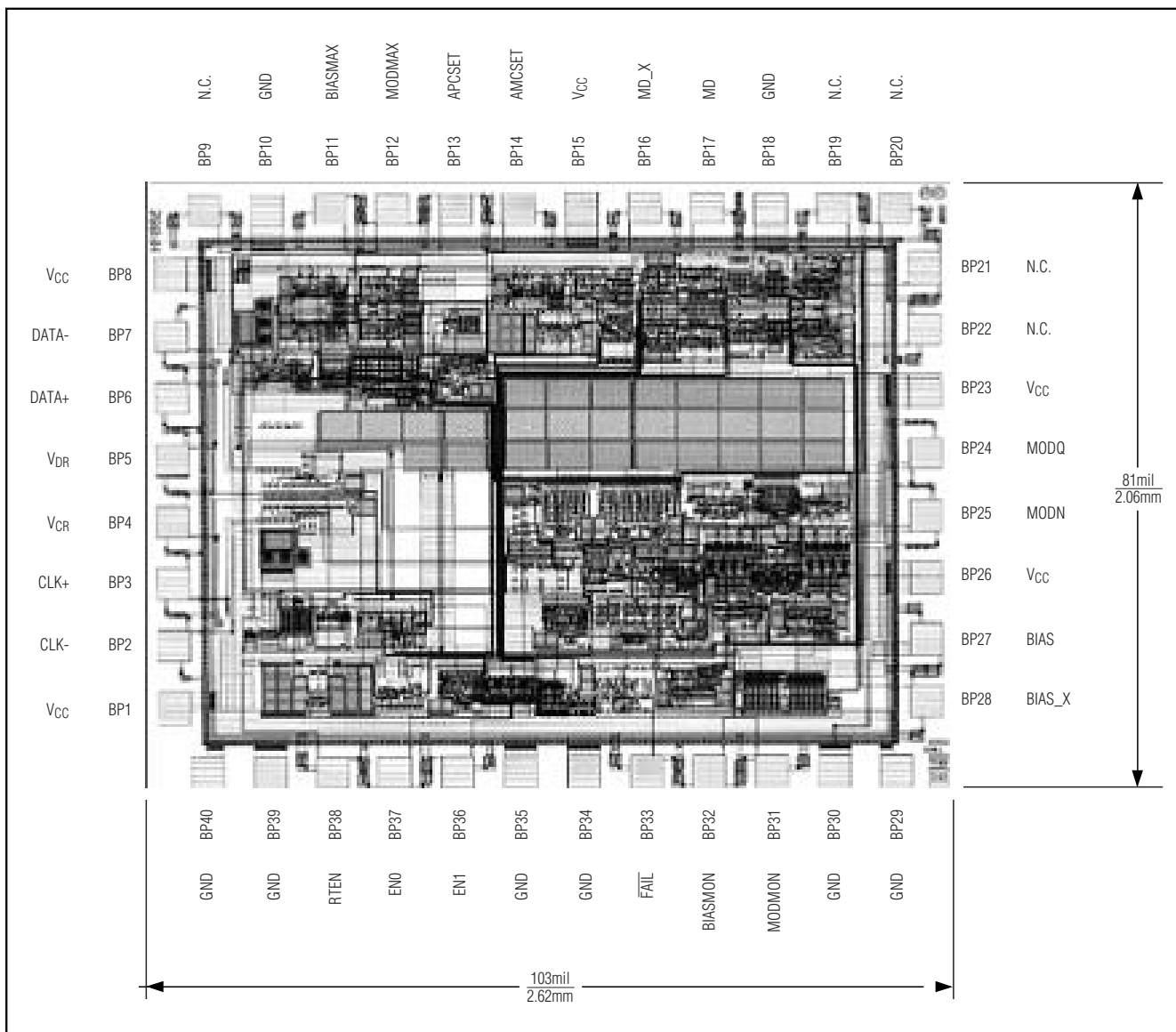

Note: N.C. means no external connection permitted. Leave these pads unconnected.

2.5Gbps Laser Driver with Automatic Modulation Control

Pad Coordinates

NAME	PAD	COORDINATES (μm)	NAME	PAD	COORDINATES (μm)
V _{CC}	BP1	46, 46	N.C.	BP21	2382, 1423
CLK-	BP2	46, 241	N.C.	BP22	2382, 1229
CLK+	BP3	46, 435	V _{CC}	BP23	2382, 1034
V _{CR}	BP4	46, 629	MODQ	BP24	2382, 840
V _{DR}	BP5	46, 824	MODN	BP25	2382, 646
DATA+	BP6	46, 1018	V _{CC}	BP26	2382, 451
DATA-	BP7	46, 1213	BIAS	BP27	2382, 257
V _{CC}	BP8	46, 1407	BIAS_X	BP28	2382, 62
N.C.	BP9	151, 1607	GND	BP29	2287, -153
GND	BP10	346, 1607	GND	BP30	2093, -153
BIASMAX	BP11	540, 1607	MODMON	BP31	1898, -153
MODMAX	BP12	735, 1607	BIASMON	BP32	1704, -153
APCSET	BP13	929, 1607	$\overline{\text{FAIL}}$	BP33	1510, -153
AMCSET	BP14	1123, 1607	GND	BP34	1315, -153
V _{CC}	BP15	1318, 1609	GND	BP35	1121, -153
MD_X	BP16	1512, 1609	EN1	BP36	926, -153
MD	BP17	1707, 1607	EN0	BP37	732, -153
GND	BP18	1901, 1607	RTEN	BP38	538, -153
N.C.	BP19	2095, 1607	GND	BP39	343, -153
N.C.	BP20	2290, 1607	GND	BP40	149, -153

Coordinates are for the center of the pad.

Coordinate 0, 0 is the lower left corner of the passivation opening for pad 1.

2.5Gbps Laser Driver with Automatic Modulation Control

Package Information

MAX3865

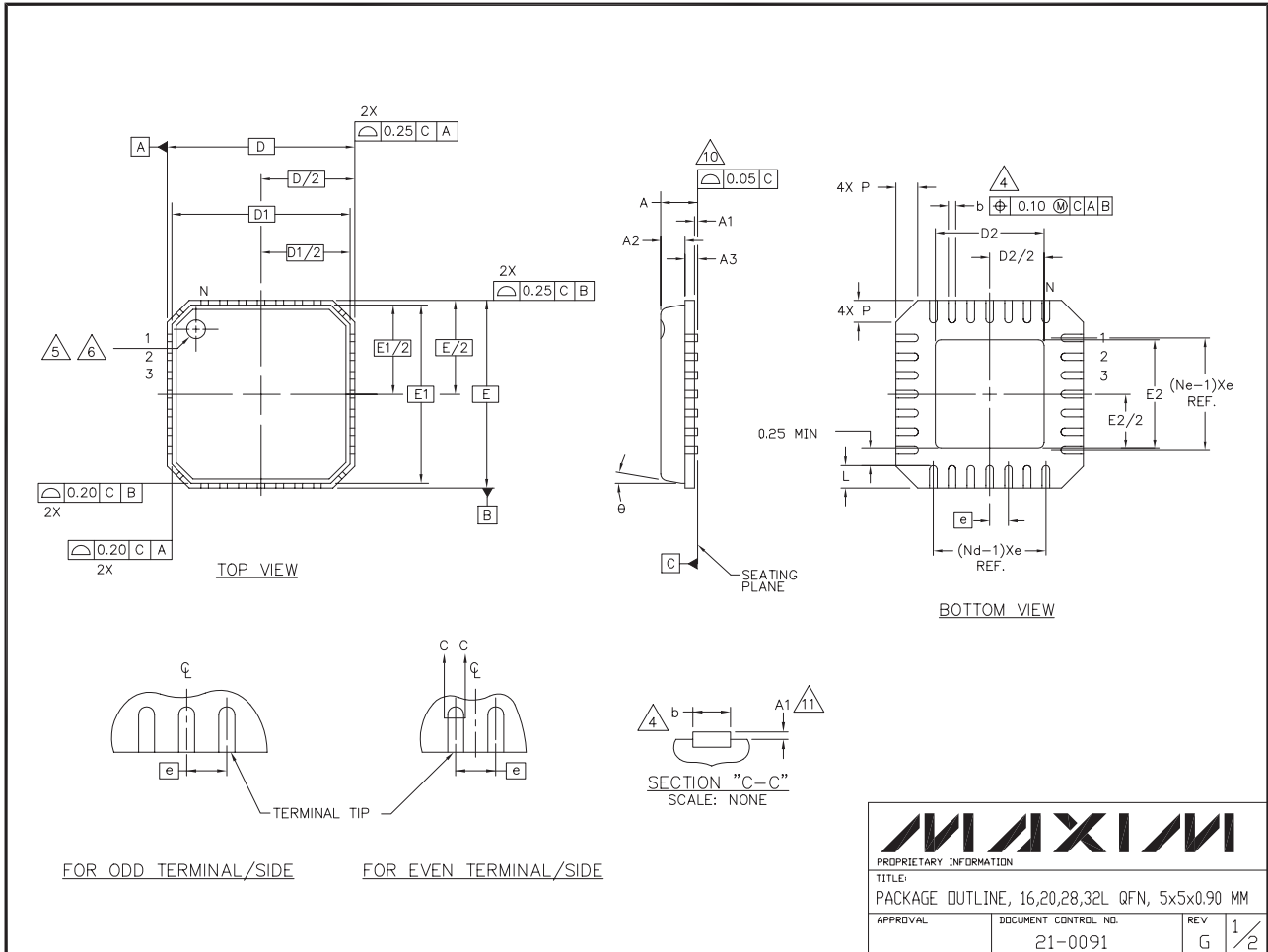

2.5Gbps Laser Driver with Automatic Modulation Control

Package Information (continued)

NOTES:

1. DIE THICKNESS ALLOWABLE IS 0.305mm MAXIMUM (.012 INCHES MAXIMUM)
2. DIMENSIONING & TOLERANCES CONFORM TO ASME Y14.5M. - 1994.
3. N IS THE NUMBER OF TERMINALS.
Nd IS THE NUMBER OF TERMINALS IN X-DIRECTION &
Ne IS THE NUMBER OF TERMINALS IN Y-DIRECTION.
4. DIMENSION b APPLIES TO PLATED TERMINAL AND IS MEASURED BETWEEN 0.20 AND 0.25mm FROM TERMINAL TIP.
5. THE PIN #1 IDENTIFIER MUST BE EXISTED ON THE TOP SURFACE OF THE PACKAGE BY USING INDENTATION MARK OR INK/ LASER MARKED.
6. EXACT SHAPE AND SIZE OF THIS FEATURE IS OPTIONAL.
7. ALL DIMENSIONS ARE IN MILLIMETERS.
8. PACKAGE WARPAGE MAX 0.05mm.
9. APPLIED FOR EXPOSED PAD AND TERMINALS.
EXCLUDE EMBEDDED PART OF EXPOSED PAD FROM MEASURING.
10. MEETS JEDEC MO220.
11. THIS PACKAGE OUTLINE APPLIES TO ANVIL SINGULATION (STEPPED SIDES) AND TO SAW SINGULATION (STRAIGHT SIDES) QFN STYLES.

SYMBOL	COMMON DIMENSIONS			No. of Terminals
	MIN.	NOM.	MAX.	
A	0.80	0.90	1.00	
A1	0.00	0.01	0.05	
A2	0.00	0.65	1.00	
A3	0.20 REF.			
D	5.00 BSC			
D1	4.75 BSC			
E	5.00 BSC			
E1	4.75 BSC			
θ	0°	-	12°	
P	0	-	0.60	
D2	1.25	-	3.25	
E2	1.25	-	3.25	

SYMBOL	PITCH VARIATION B			No. of Terminals	SYMBOL	PITCH VARIATION B			No. of Terminals	SYMBOL	PITCH VARIATION C			No. of Terminals	SYMBOL	PITCH VARIATION D			No. of Terminals
	MIN.	NOM.	MAX.			MIN.	NOM.	MAX.			MIN.	NOM.	MAX.			MIN.	NOM.	MAX.	
Ⓢ	0.80 BSC				Ⓢ	0.65 BSC				Ⓢ	0.50 BSC				Ⓢ	0.50 BSC			
N	16			3	N	20			3	N	28			3	N	32			3
Nd	4			3	Nd	5			3	Nd	7			3	Nd	8			3
Ne	4			3	Ne	5			3	Ne	7			3	Ne	8			3
L	0.35	0.55	0.75		L	0.35	0.55	0.75		L	0.35	0.55	0.75		L	0.30	0.40	0.50	
b	0.28	0.33	0.40	4	b	0.23	0.28	0.35	4	b	0.18	0.23	0.30	4	b	0.18	0.23	0.30	4

PROPRIETARY INFORMATION			
TITLE: PACKAGE OUTLINE, 16,20,28,32L QFN, 5x5x0.90 MM			
APPROVAL	DOCUMENT CONTROL NO.	REV	
	21-0091	G	2/2

Maxim cannot assume responsibility for use of any circuitry other than circuitry entirely embodied in a Maxim product. No circuit patent licenses are implied. Maxim reserves the right to change the circuitry and specifications without notice at any time.

16 **Maxim Integrated Products, 120 San Gabriel Drive, Sunnyvale, CA 94086 408-737-7600**